

XE 60 - 70 - 80

Technical data



designed to work



XE 60 - 70 - 80 Technical data

VDI 2198

			OM PIMESPO	OM PIMESPO	OM PIMESPO		
Specifications	1.1	Manufacturer					
	1.2	Manufacturer's type designation	XE 60	XE 70	XE 80		
	1.3	Drive: electric - diesel - petrol - L.P.G.- mains electric	Electric	Electric	Electric		
	1.4	Operator type: Hand operated – on foot – standing – seated operator	Seated driver	Seated driver	Seated driver		
Weights	1.5	Capacity / "Load"	Q (t)	6,0	7,0	8,0	
	1.6	Load centre distance	c (mm)	600	600	600	
	1.8	Distance to fork plate from front axle	x (mm)	600	630	630	
	1.9	Wheelbase	y (mm)	2000	2000	2000	
	2.1	Weight in working order	kg	10020-10100 (dual-mounted)	11150-11230 (dual-mounted)	12220 (dual-mounted)	
	2.2	Axle weight with nominal load front / rear	kg	14125/1895 ¹⁾	16030/2120 ¹⁾	17530/2690	
	2.3	Axle dead weight front / rear	kg	4525/5495 ²⁾	4725/6425 ³⁾	5010/7210	
	3.1	Tyres SE = superelastic - CU = cushion - PN = pneumatic tyres		SE / SE ³⁾	SE / SE ³⁾	SE / SE ³⁾	
	3.2	Dimensions front wheels		355/65 -15 ³⁾	355/65 -15 ³⁾	8.25 - 15 ³⁾ (dual-mounted)	
	3.3	Rear wheel dimensions		250-15	250-15	250-15	
Wheels and tyres	3.5	Wheels: N° front / N° rear (x = drivewheels)		2 (4) x 2	2 (4) x 2	4 x 2	
	3.6	Front tread	b10 (mm)	1490 - 1585 (dual-mounted)	1490 - 1585 (dual-mounted)	1585	
	3.7	Rear tread	b11 (mm)	1545	1545	1545	
	Overall dimensions	4.1	Tilt lifting group	forward / reverse	Grad	7°/11° ⁴⁾	7°/11° ⁴⁾
		4.2	Minimum overall lift height		h1 (mm)	2775	2775
		4.3	Free lift		h2 (mm)	150	150
		4.4	Lifting height		h3 (mm)	3280	3280
		4.5	Maximum overall lift height		h4 (mm)	4900	4900
		4.7	Height of operator's overhead protection guard		h6 (mm)	2515	2515
	4.8	Seat height		h7 (mm)	1475	1475	
4.12	Towing hook height		h10 (mm)	525	525		
4.19	Overall length		l1 (mm)	4360	4390		
4.20	Length including fork thickness		l2 (mm)	3160	3190		
4.21	Maximum width		b1/b2 (mm)	1840 - 2100 (dual-mounted)	1840 -2100 (dual-mounted)	2100 (dual-mounted)	
4.22	Fork dimensions		s/e/l (mm)	1200/130/60	1200/150/70	1200/150/70	
4.23	Fork holder plate according to DIN 15173 Class / Form A, B			4-A ⁵⁾	4-A ⁵⁾	4-A ⁵⁾	
4.24	Width fork holder plate		b3 (mm)	1800/2000 (dual-mounted)	1800/2000 (dual-mounted)	2000 (dual-mounted)	
4.31	Mast height from ground (braking of load)		m1 (mm)	170	170	170	
4.32	Centre from ground (braking of load)		m2 (mm)	195	190	190	
4.33	Aisle width with 800 x 1200 pallet and 1200 side loading		Ast (mm)	4930	4960	4960	
4.34	Aisle width with 800 x 1200 pallet and 800 side loading		Ast (mm)	4930	4960	4960	
4.35	Turning circle		Wa (mm)	2930	2930	2930	
4.36	Minimum distance from the truck centre line rotation travel speed		b13 (mm)	990	990	990	
Performance	5.1	Travel speed	loaded / unloaded	km/h	11,5/13,5	11/13	
	5.2	Lift speed	loaded / unloaded	m/s	0,21/0,31	0,20/0,30	
	5.3	Lift descent speed	loaded / unloaded	m/s	0,43/0,41	0,43/0,41	
	5.5	Drive pull to hitchbar (S2 60 min)	loaded / unloaded	N	10800/10400	10700/10300	
	5.6	Max drive pull to hitchbar (S2 5 min)	loaded / unloaded	N	19800/18800	19900/18700	
	5.7	Surmountable gradient (S2 30 min)	loaded / unloaded	%	8,5/13	7,5/11,5	
	5.8	Surmountable gradient (S2 5 min)	loaded / unloaded	%	13/20	11,5/18	
	5.9	Acceleration time (10 m)	loaded / unloaded	s	5,4/4,8	5,8/5,1	
	5.10	Service brake			Mechanical-Hydraulic	Mechanical-Hydraulic	
	Electric motor	6.1	Drive motor power S2 60 min	kW	20	20	
6.2		Lift motor, power S3 15%	kW	22	22		
6.3		Battery according to DIN 43531/35/36 A,B,C, N0		NO	NO		
6.4		Voltage, Battery capacity K5	V / Ah	80 (2x40) / 700 ⁵⁾	80 (2x40) / 800 ⁵⁾		
6.5		Battery weight	kg	2160 (2 x 1080)	2520 (2 x 1260)		
6.6		Energy consumption according to VDI	kWh/h	15	16,5		
Other	8.1	Cycle drive command type		Electronic	Electronic		
	8.2	Equipment work pressure	bar	170	170		
	8.3	Oil range for equipment (max available)	l/min	60	60		
	8.4	Sound level at drivers ear	dB (A)	-	-		
	8.5	Towing hook, model / type DIN		-	-		

1) XE 60 14,135/1,820 kg, Dual-mount.
XE 70 16,040/2,045 kg, Dual-mount
2) XE 60 4,535/5,420 kg, Dual-mount.
XE 70 4,735/6,350 kg, Dual-mount.
3) For alternative wheels see attached table

4) XE 60-70-80 3°/7° with DX and TX masts
5) XE 60 80/800 V/Ah
XE 70 80/950; 1050 V/Ah
XE 80 80/1,050 V/Ah

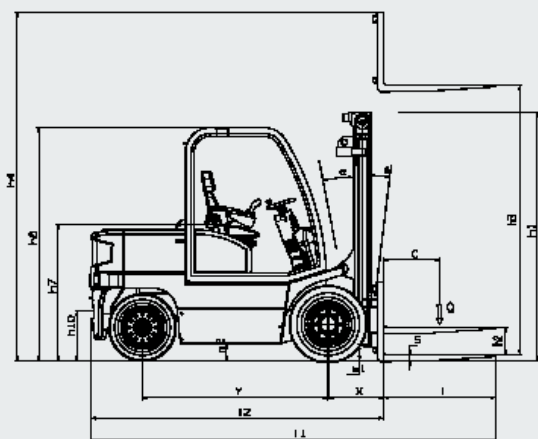

Safety distance = 200mm

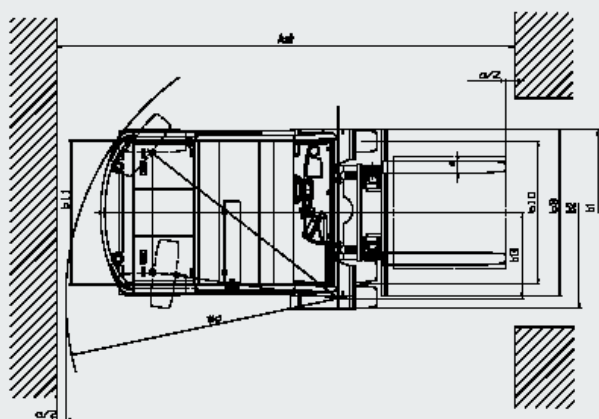

ALTERNATIVE LIFT CHARACTERISTICS

				Standard (Simplex)						Duplex GAL					Triplex GAL						
XE 60	Lift height	h_3	mm	3280	3560	3960	4480	4960	5480	3260	3560	3760	3960	4360	4360	4660	5160	5560	5960	6560	6960
	Minimum verall height	h_1	mm	2775	2850	3050	3375	3550	3875	2430	2610	2680	2810	2980	2330	2430	2600	2805	2915	3195	3380
	Max. overall height	h_4	mm	4900	5170	5570	6100	6570	7100	4275	4605	4775	5005	5375	5405	5675	6175	6600	6975	7600	8050
	Free lift height	h_2	mm	150	150	150	150	150	150	1480	1660	1730	1800	2030	1340	1440	1610	1825	1925	2215	2325
XE 70	Lift height	h_3	mm	3280	3560	3960	4480	4960	5480	3260	3560	3760	3960	4360	4360	4660	5160	5560	5960	6560	6960
	Minimum verall height	h_1	mm	2775	2855	3055	3375	3565	3875	2530	2710	2780	2910	3080	2425	2530	2700	2910	3015	3300	3480
	Max. overall height	h_4	mm	4900	5180	5580	6100	6580	7100	4350	4680	4850	5080	5450	5475	5750	6250	6680	7050	7680	8130
	Free lift height	h_2	mm	150	150	150	150	150	150	1500	1680	1750	1880	2050	1345	1440	1610	1820	1925	2210	2325
XE 80	Lift height	h_3	mm	3280	3560	3960	4480	4960	5480	3260	3560	3760	3960	4360	4360	4660	5160	5560	5960	6560	6960
	Minimum verall height	h_1	mm	2775	2855	3055	3375	3565	3875	2630	2810	2880	3010	3180	2530	2630	2800	3010	3115	3400	3580
	Max. overall height	h_4	mm	4900	5160	5580	6100	6560	7100	4450	4780	4950	5180	5550	5580	5850	6350	6780	7150	7780	8225
	Free lift height	h_2	mm	150	150	150	150	150	150	1500	1680	1750	1880	2050	1345	1440	1610	1820	1925	2210	2325

TYRES

Type	Superelastic (SE)		Pneumatic (PN)	
	Front	Rear	Front	Rear
XE 60	355/65 -15	250 - 15	355/65 - 15 /24 p.r.	250 - 15/18 p.r.
	8.25 - 15 (dual-mounted)	250 - 15	8.25 -15/16 p.r. (dual-mounted)	250 - 15/18 p.r.
XE 70	355/65 -15	250 - 15	355/65 -15/24 p.r.	250 - 15/18 p.r.
	8.25 - 15 (dual-mounted)	250 - 15	8.25-15/16 p.r. (dual-mounted)	250 - 15/18 p.r.
XE 80	-	-	-	-
	8.25 - 15 (dual-mounted)	250 - 15	8.25-15/16 p.r. (dual-mounted)	250 - 15/18 p.r.





XE 60 - 70 - 80

A truck designed for heavy work, suitable for many jobs, characterised by robustness, reliability and top class versatility.

The new **chassis** developed with finished element technology (F.E.M.) guarantees high torsional rigidity and better drive characteristics.

The front drive relies on a powerful 80 V drive motor with 20 Kw power. A powerful lift motor with 22 Kw power supplies high speed lifting.

The **Mosfet technology electronic control** ensures quick and precise command response and manages the braking, phase, thus saving energy.

Smooth starting and gradual parking, powerful and progressive acceleration characterise the truck, all in the name of maximum flexibility and productivity.

The **hydraulic system**, with proportional electro-valves, guarantees maximum performance even when it comes to delicate handling of goods.

The regenerative electric **braking**, which acts on the release of the accelerator, in reverse gear and during brake pedal operation, appreciably lightens ease of drive guaranteeing precision particularly in the phases of parking.

Productivity also means a **comfortable driving position**. The new Grammer MSG85 seat guarantees maximum comfort and it has, as standard, armrest with **joystick** incorporated which means that all the hydraulic functions of the machine are under control. Standard features such as completely hydraulic power steering, adjustable steering column both in inclination and in depth and a clear display next to the operator guarantee excellent control over operations.

The overhead protection guard cover is standard: on request the various options for operator cabins mean further higher quality on board the truck.

80 V **batteries** with capacities from 700 to 1050 Ah.

A **forklift truck** characterised by enhanced profiles guarantees better visibility and elevated residual carrying capacity. Simplex, duplex and triplex lifting struts with elevation up to 6960 mm.

Options: full lighting, working lights, flashers, acoustic reversing indicator, 4 and 5 way distributor, various cabin options, load support grill, integrated sideways movement, pneumatic tyres, dual-mounted tyres, cushion tyres, different length forks, simplex, duplex and triplex lifts.

The technical specifications quoted are given as an indication. OM PIMESPO reserves the right to modify them without notice.